

196-125 PLINTH LIFT STORAGE

ETAPE 1

Ancrer les rails/longerons de la base de storage aux ancrages internes de la tete de lit.
Ancrer la base du pied de lit de storage aux rails/longerons de la base.

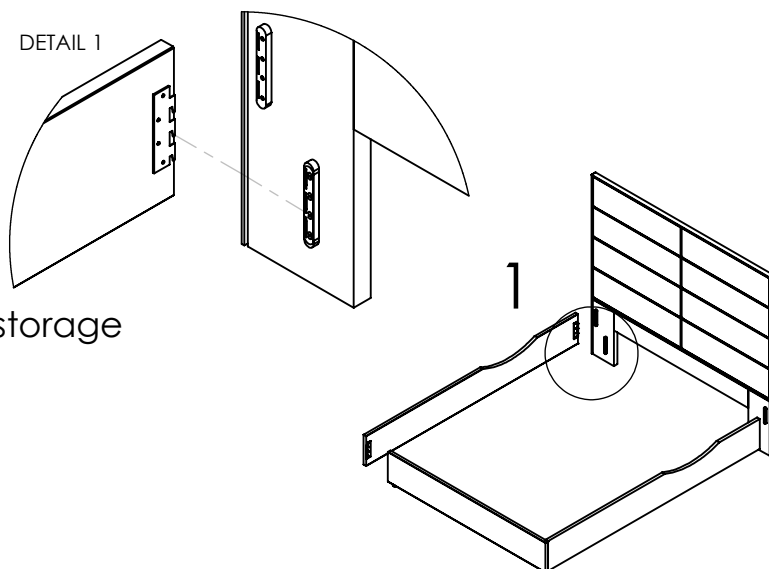

ETAPE 2

Ancrer les longerons a la tete de lit.
Boulonner le pied de lit aux longerons avec les boulons et la cle allen fournis.
(Le haut du pied de lit et le haut des longerons sont a egalite/flush)

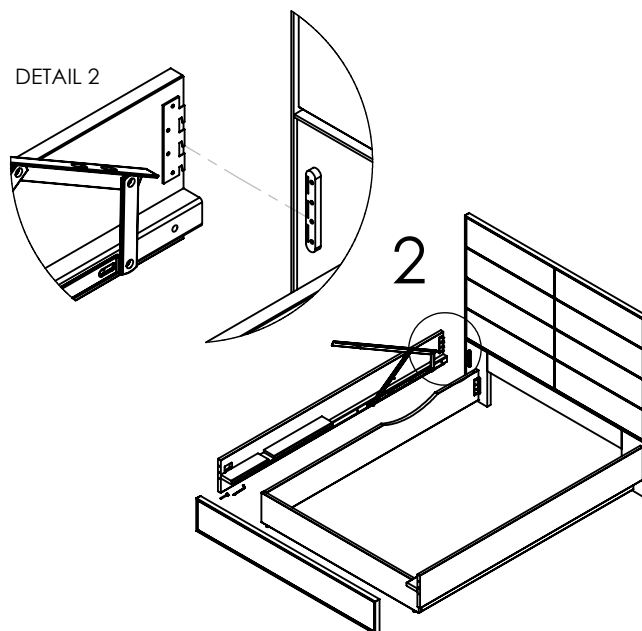
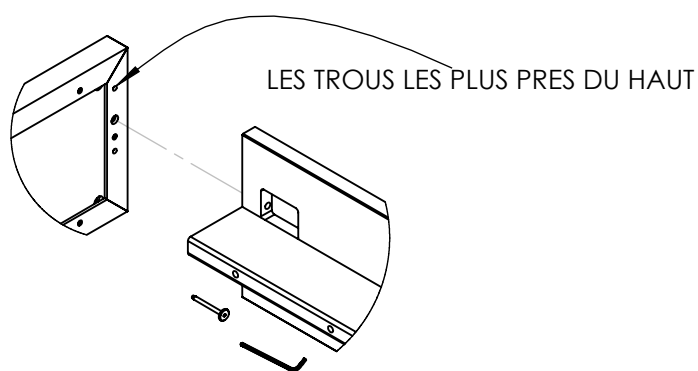

ETAPE 3

Boulonner le cadre des lattes aux bras d'extension en utilisant les 4 boulons et noix fournis.
Attacher les pistons aux bras d'extension avec les noix fournis.
Attacher le pied du centre au cadre a lattes avec la noix fournis.

****Le matelas doit etre sur le mecanisme pour que la base reste fermee****

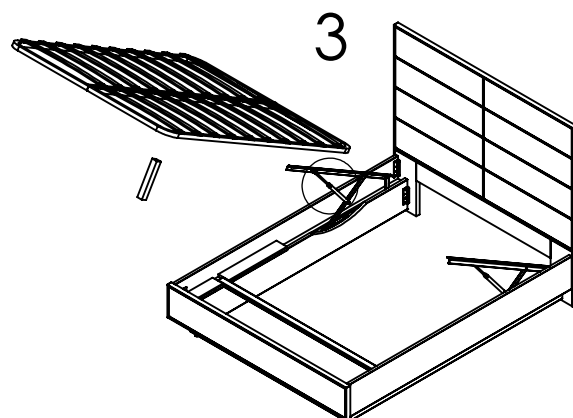
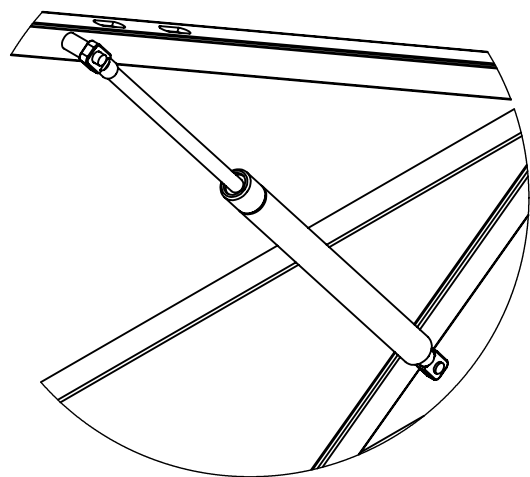

196-125 PLINTH LIFT STORAGE

STEP #1

Hook storage base rails to inside hooks on headboard.
Hook storage base footboard to storage base rails.

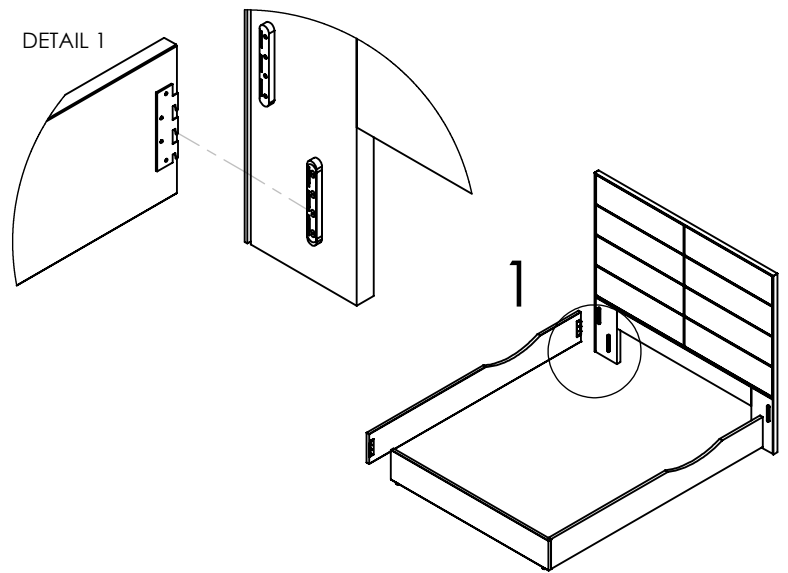

STEP #2

Hook siderails to headboard.
Bolt footboard to siderails using bolts and allen key provided.

(Footboard top fits flush with siderail top.)

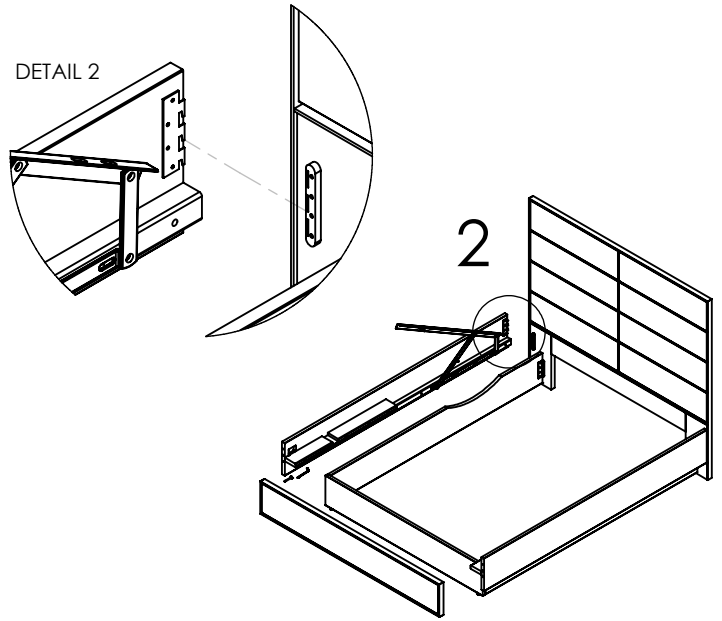
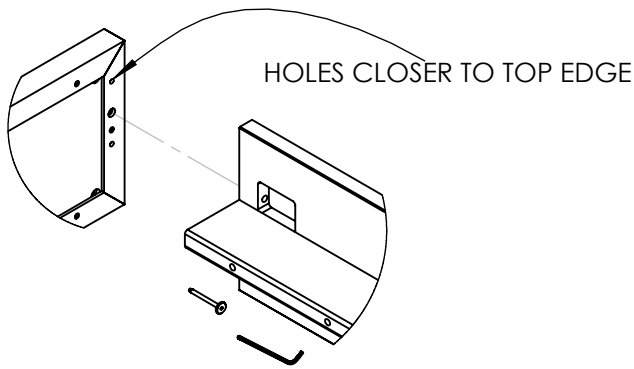

STEP #3

Bolt slat frame to lift arms using 4 bolts and nuts provided.
Attach struts to lift arms using nuts provided.
Attach center foot to center of slat frame using nut provided.

Mattress must be on mechanism for it to stay down.

