

196-145 PLINTH LIFT STORAGE

STEP #1

Hook storage base rails to inside hooks on headboard. Hook storage base footboard to storage base rails.

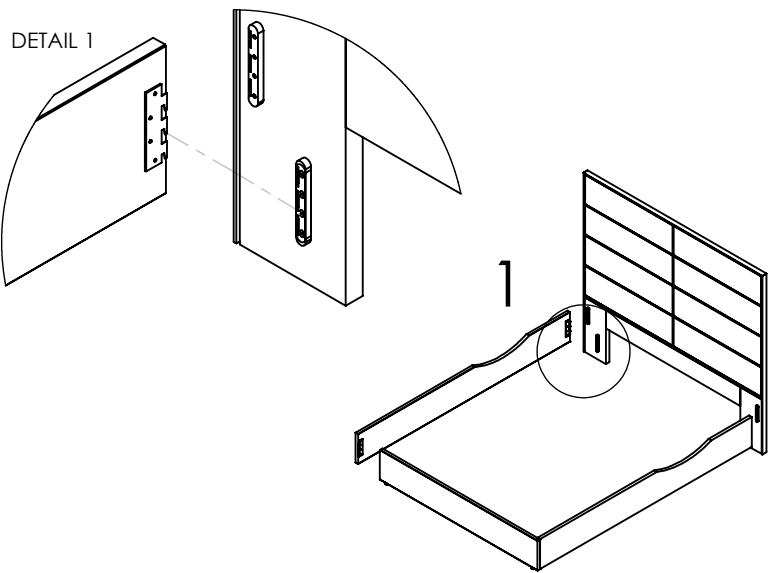

STEP #2

Hook siderails to headboard. Bolt footboard to siderails using bolts and allen key provided.

(Footboard top fits flush with siderail top.)

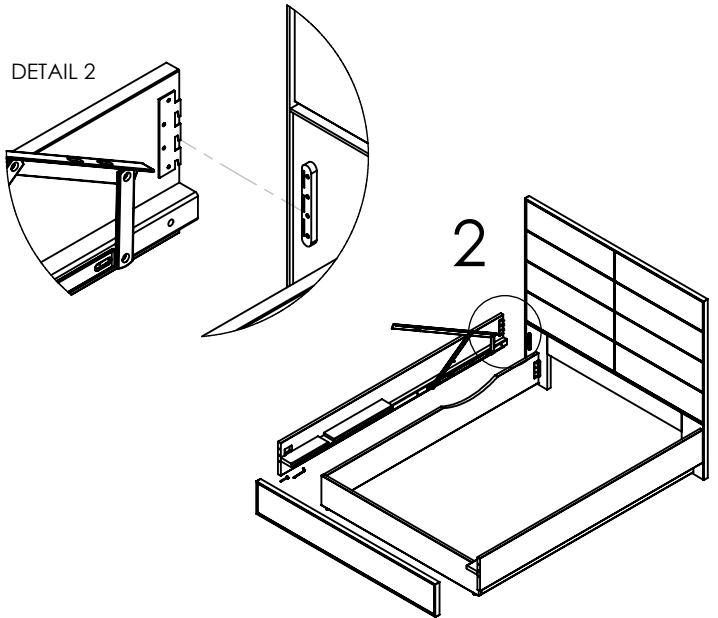
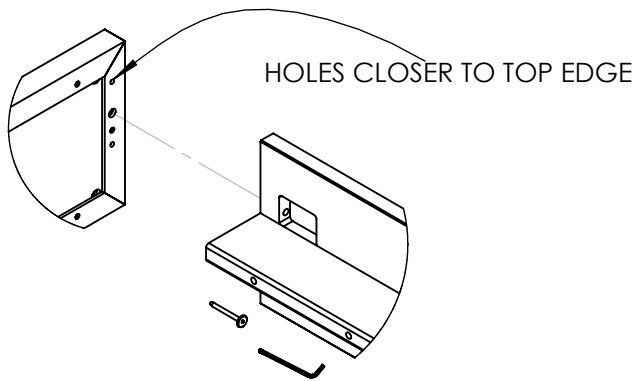

STEP #3

Bolt wood supports to bottom of slat frame. Attach 2 short center feet to wood supports. Attach center foot to center of slat frame using nut provided. Bolt slat frame to lift arms using 4 bolts and nuts provided. Attach struts to lift arms using nuts provided.

Mattress must be on mechanism for it to stay down.

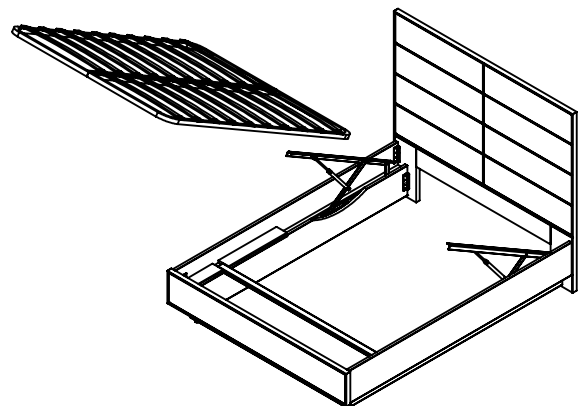
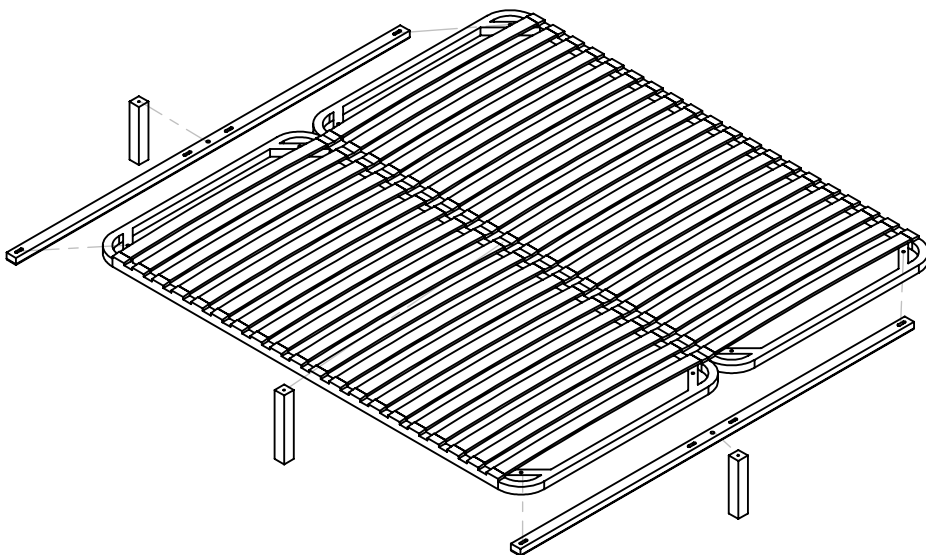

196-145 PLINTH LIFT STORAGE

ETAPE 1

Ancrer les rails/longerons de la base de storage aux ancrages intérieurs de la tête de lit.
Ancrer la base du pied de lit de storage aux rails/longerons de la base.

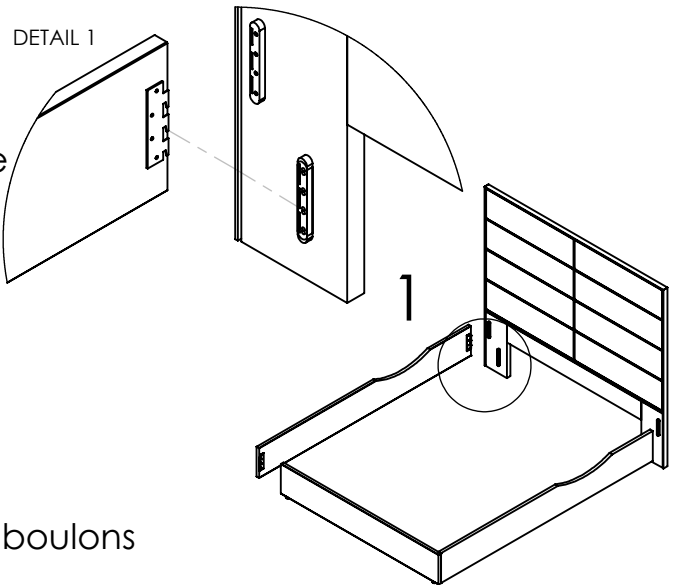

ETAPE 2

Ancrer les longerons a la tête de lit.
Boulonner le pied de lit aux longerons avec les boulons et la cle allen fournis.
(Le haut du pied de lit et le haut des longerons sont à égalité/flush)

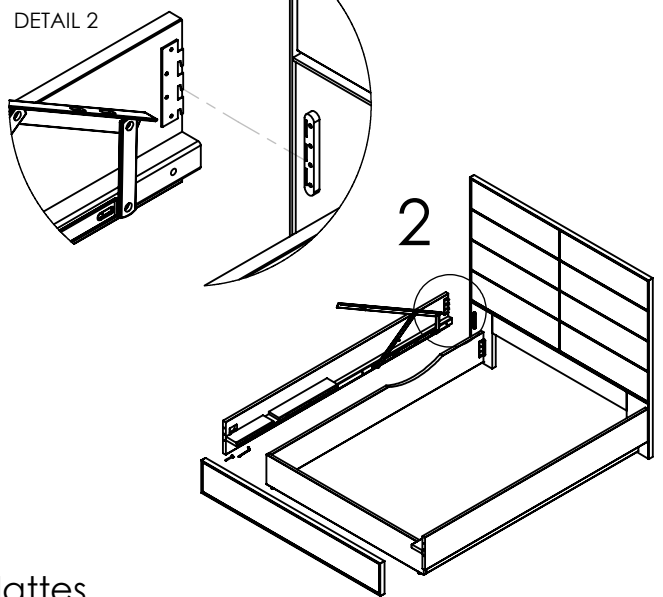
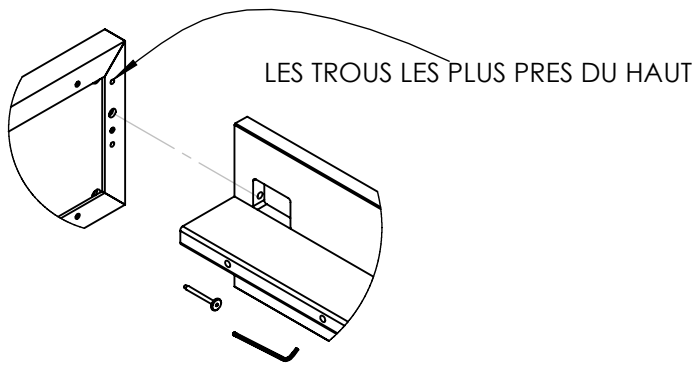

ETAPE 3

Boulonner les supports en bois au bas du cadre à lattes.
Attacher les 2 pieds central aux supports de bois.
Attacher le pied du centre au cadre à lattes avec la noix fournis.
Attacher l'amortisseur aux bras du levier en utilisant les noix fournis.

Le matelas doit être sur le mécanisme pour que la base reste fermée

